

# DeepWater Digital

## Submersible Tiltmeter

The DeepWater Digital is a precision digital tiltmeter designed for underwater measurements and other applications in high-pressure or corrosive environments.

The housing is machined from a solid block of 316 stainless steel and incorporates a high-pressure, underwater-mateable neoprene connector.



### CONTINUOUS MONITORING

Inside are one or two gravity-referenced electrolytic tilt sensors and our low-noise electronics, delivering precision, high dynamic range and long-term stability under the most demanding conditions. DeepWater tiltmeters are excellent choices for offshore applications and for monitoring dams, pipelines and underwater machinery. DeepWater tiltmeters are also available with 4-20 mA and analog voltage outputs.



Submersible Tiltmeter

	DEE/WATER/DIGITAL (STANDARD)	DEE/WATER/DIGITAL (WIDE ANGLE)
ANGULAR RANGE	±0.5 degrees	±3 degrees
RESOLUTION	0.002 degrees	0.02 degree
REPEATABILITY	0.002 degree	0.02 degree
TEMPERATURE COEF.	0.001 degree/°C typical	0.01 degree/°C typical
CHANNELS	Single-Axis or Dual-Axis with 2 Orthogonal Tilt Channels, 1 Temperature Channel	
TIME CONSTANT	0.15 second	
DIGITAL OUTPUT	RS232 or RS485, transmit and receive. Baud rate: 9600 (default), 19200, 28800, 57600, 115200, 230400. NMEA 0183 compatible (x, y, temperature, serial no.)	
OUTPUT DATA RATE	User-selectable from 10 samples/second to 1 sample/24 hours	
POWER	7 to 25 VDC @ 27 mA, 250 mV peak-to-peak ripple maximum, reverse polarity protected	
ENVIRONMENTAL	-25° to +70°C operational, -30° to +100°C storage. Case rated to 3500 psi (240 bars), tested to failure at 7000 psi (480 bars)	
MOUNTING	Four no. 10 stainless steel mounting screws.	
MATERIALS	316 stainless steel	
CONNECTORS	6-pin neoprene, underwater mateable	
SIZE & WEIGHT	152 x 102 x 89 mm (6 x 4 x 3.5 inches), 5 kg (11 lb)	

CONNECTOR PIN	WIRE COLOR IN CABLE	FUNCTION	FUNCTION (RS485 VERSION)
1	Black	Ground	Ground
2	White	not used	Tx-
3	Red	Power	Power
4	Green	Rx	Tx+
5	Yellow (Orange)	not used	Rx-
6	Blue	Tx	Rx+

#### ORDER CODES

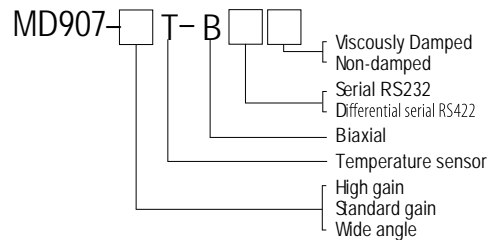

#### USEFUL ACCESSORIES:

- 70304 PVC-jacketed cable, 6mm dia. specify length
- SO-20/6 Neoprene cable, 9mm dia. specify length
- SPLICE Waterproof cable splice

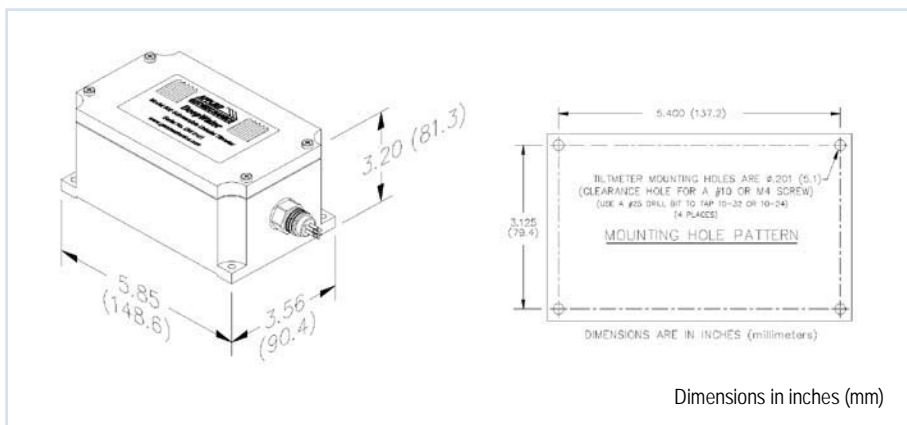

**es&s** - DISTRIBUTOR

environmental systems & services  
 8 River Street, Richmond VIC 3121 Australia  
 T + 61 3 8420 8999 | F + 61 3 8420 8900  
 geotechnical@esands.com | [www.esands.com](http://www.esands.com)

