

Model 84053

Ceramic Sensor

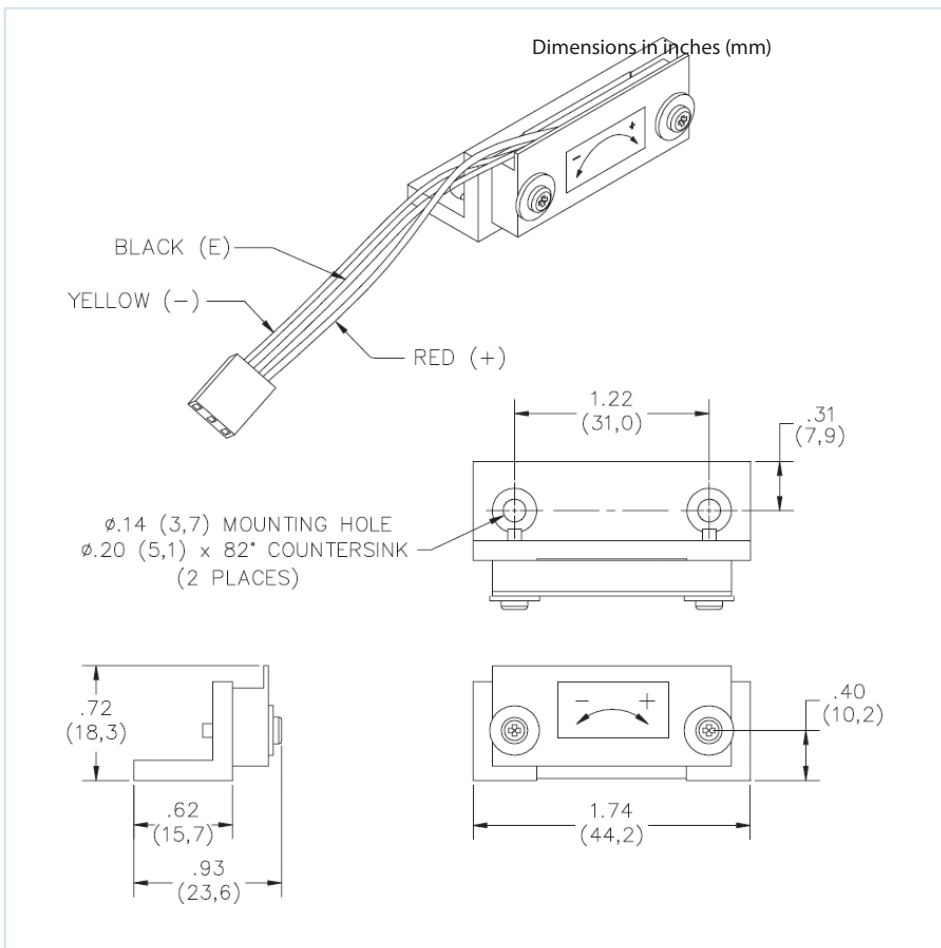

SPECIFICATIONS	
FULL ANGULAR RANGE	±6 degrees (12 degrees span)
LINEAR RANGE	±3 degrees (6 degrees span)
RESOLUTION	< .0001 degree (<1.75 microradians)
REPEATABILITY (STATIC)	< .0002 degree (<3.5 microradians)
LINEARITY (LINEAR RANGE)	< 2% of span
LINEARITY (FULL RANGE)	< 8% of span
NULL IMPEDANCE @20° C	12,000 Ohms ±20%
OPERATING TEMPERATURE	-50° C to +125° C
STORAGE TEMPERATURE	-75° C to +150° C
TIME CONSTANT	150 milliseconds typical
NATURAL FREQUENCY	3 Hz
SCALE FACTOR TEMP. COEF., Ks	+0.04% /°C typical
ZERO SHIFT TEMP. COEF., Kz	±.0002 degree/°C typical
WEIGHT	24 grams
SIGNAL CONDITIONING	All Applied Geomechanics signal conditioners



- DISTRIBUTOR

environmental systems & services
 8 River Street, Richmond VIC 3121 Australia
 T + 61 3 8420 8999 | F + 61 3 8420 8900
 geotechnical@esands.com | www.esands.com

