

# Model MD900-T

Digital and Analog Clinometer

Our Model MD900-T is an economical biaxial clinometer with powerful features typically associated with more expensive instruments. Many thousands are in use

today for antenna positioning, surface and subsea marine applications, structural and geotechnical monitoring, and industrial test and measurement.



## ECONOMICAL BIAxIAL CLINOMETER

Recently upgraded with our "IRIS" electronics, the new MD900-T has lower power consumption, more firmware features and greater reliability than ever before. The internal sensor is a liquid-filled electrolytic transducer with no mechanical moving parts. The clinometer is housed in an easily mountable NEMA 4X (IP65) enclosure. Output data (X tilt, Y tilt, Temperature, Serial no.) are provided in several digital formats, and data are easily graphed and logged with our ZAGI user-interface software, included with every unit.

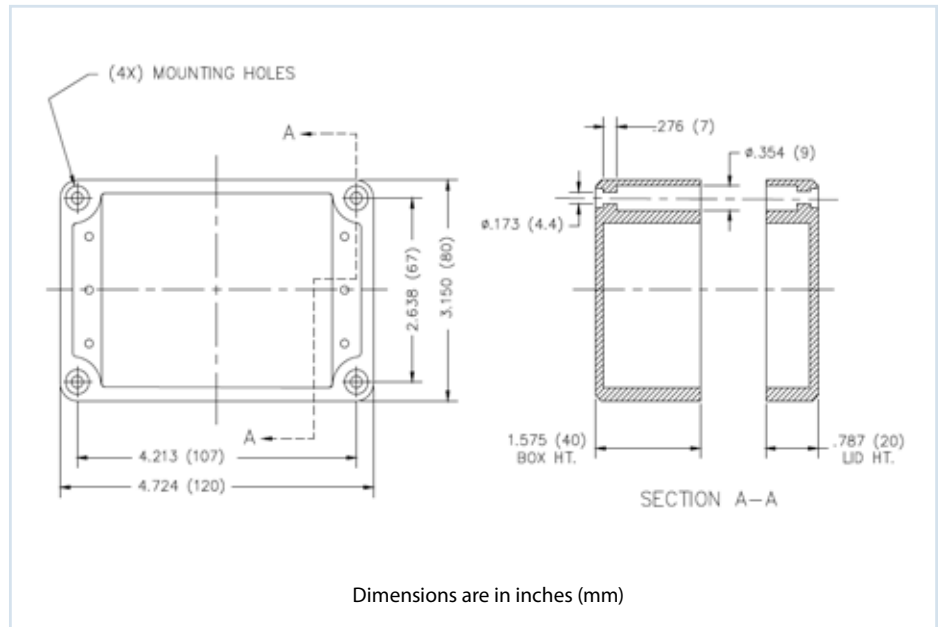

	HIGH-GAIN VERSION	STANDARD VERSION	WIDE-ANGLE VERSION
ANGULAR RANGE	±10 degrees	±25 degrees	±50 degrees
RESOLUTION	0.002 degree	0.004 degree	0.01 degree
REPEATABILITY	0.01 degree (static)	0.01 degree (static)	0.02 degree (static)
HYSTERESIS	0.02 degree	0.02 degree	0.04 degree
LINEARITY	1% of full span typical	1% of full span typical	1% of full span typical
DIGITAL OUTPUT	RS232 standard, RS485 (RS422) available, transmit and receive. Two orthogonal tilt angles plus temperature and serial no. Baud rate: 9600 (default), 19200, 28800, 57600, 115200, 230400. Formats: NMEA XDR, Trimble proprietary, Ashtech compatible, simple (X, Y, Temperature, Serial No.)		
ANALOG OUTPUT	X and Y tilt channels: 0-4.75 Volts DC, single-ended		
TIME CONSTANT, T	0.15 second; output is proportional to $1-e^{-t/T}-0.01e^{-t/5000T}$ where t is time in seconds		
NATURAL FREQUENCY	7 Hz		
TEMPERATURE COEF.	Span: <0.02%/°C typical. Zero (bias): 10 arc seconds/°C typical. Lower values available.		
POWER REQUIREMENTS	7-28 VDC @ 30 mA, 250 mV peak to peak ripple max., reverse polarity and surge protected. 12V wall transformer included		
ENVIRONMENTAL	40° to +85° C operating and storage; 100% humidity, not submersible; IP65 (NEMA 4X) rating		
ENCLOSURE	Painted, die cast aluminum box, 120 x 80 x 60 mm. 1.8m (6 ft) cable included.		
WEIGHT	550g (1.2 lb)		

\* greater range available

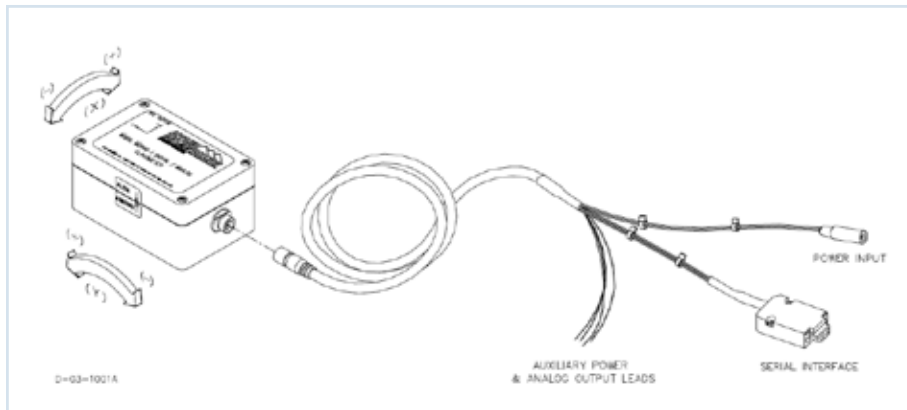

Model MD900-T Digital/Analog Clinometer with Part No. 84033 Cable Whip (Included)

**ORDER CODES:**

**USEFUL ACCESSORIES:**

- 84033 Additional 1.8m (6 ft) cable whip, terminated
- 66166-01 1.8m (6 ft) cable whip, unterminated
- 00254-02 Additional 12V wall transformer
- 84051 Horizontal mounting plate
- 81439 Vertical mounting bracket

CIRCULAR CONNECTOR PIN	WIRE COLOR	FUNCTION	DB9 CONNECTOR PIN
1	Red-White	Ground	5
2	Red	Power (7-28 VDC)	—
3	Green	Analog X Out	—
4	Red-Yellow	Receive Data (RXD)	3
5	Red-Black	Transmit Data (TXD)	2
6	Red-Blue	Analog Y Out	—



environmental systems & services  
 8 River Street, Richmond VIC 3121 Australia  
 T + 61 3 8420 8999 | F + 61 3 8420 8900  
 geotechnical@esands.com | [www.esands.com](http://www.esands.com)

