

BOREHOLE EXTENSOMETER (DISPLACEMENT SENSOR)

Model BOR-EX

APPLICATIONS

The displacement sensor used with a borehole extensometer makes it possible to control, with precision, the stability of:

- Foundations, solid masses around tunnels or any other type of cavity
- Embankments
- Excavations or natural slopes

DESCRIPTION

The sensor measures relative displacement between the superior free end part of the extension rod reference tip, which is integral to the anchor, and the reference plate or the extensometer head.

Two categories of displacement sensor are available. The first one allows manual readings using a dial indicator or a depth gauge. A single sensor can be used to read several measurement points. The second category allows remote electrical readings and includes vibrating wire and potentiometer sensors. In this case, a single sensor is required for each measurement point.

FEATURES

- Easy automated remote reading
- Possibility for manual readings: mechanical and electrical simultaneously

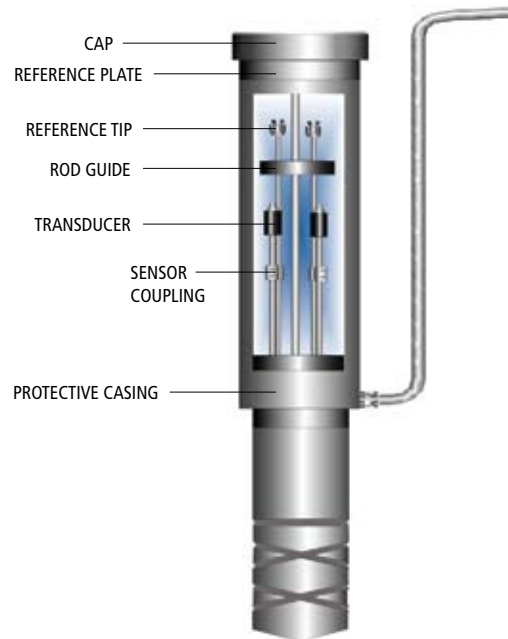

Multiple point extensometer head BOR-EX with vibrating wire sensors

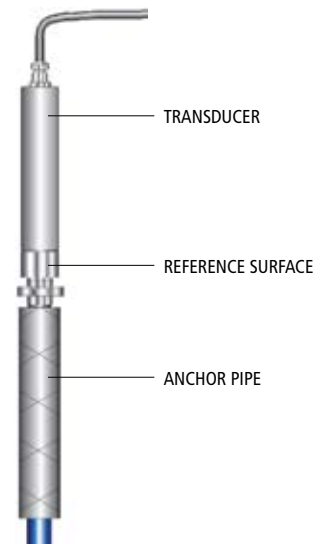

Single point extensometer head with potentiometer

SPECIFICATIONS

	DIAL INDICATOR	DEPTH GAUGE	VIBRATING WIRE SENSOR	POTENTIOMETER
Range	0–50 mm	0–150 mm	0–150 mm	0–150 mm
Accuracy	—	±0.003 mm	±0.25% F.S.	±0.5% F.S.
Resolution	0.01 mm	LCD: 0.001 mm Vernier: 0.01 mm	0.02% F.S.	0.01 mm
READINGS				
Readout unit	—	—	MB-6T(L)	PALMETO P5
DAS	—	—	SENSLOG	SENSLOG
Operating temperature	—	0 to +40°C (LCD)	–20 to +80°C	–20 to +80°C
Thermistor	—	—	3k (see model TH-T)	Available on request
Electrical cable	Multiconductor with variable numbers of twisted shielded pairs (according to number of sensors per extensometer) grounded, PVC jacket (standard), with thermistor			
Electrical head housing	Including a PVC protective tube with variable overall dimensions, a stainless steel reference plate and a protective cap, all splash proof			

ORDERING INFORMATION

Please specify:

- Number of measuring points
- Type and range of sensors
- Cable length
- Readout instruments



Depth gauge



Dial Indicator