

BOREHOLE EXTENSOMETER

Model BOR-EX

APPLICATIONS

The borehole extensometer Model BOR-EX allows for measurements of precise longitudinal displacements in rock or soil masses. The system can be supplied with a single anchor point, or multiple points. It is used in the analysis of performance and safety in the following areas:

- Foundations
- Embankments
- Excavations
- Natural slopes
- Tunnels

DESCRIPTION

The borehole extensometer is a simple and practical instrument including:

- Anchors (single or multiple points)
- Extension rod (fiberglass or stainless steel with protective tube)
- Head (manual or automatic measurement – see separate datasheet)

The anchor is connected to the head of the instrument by extension rods placed within a protective sleeve. This sleeve ensures that the rods can move freely and translate all movement of the anchor to the tip of the rod. Movement of the rock or soil mass relative to the head can then be calculated by measuring the displacement of the tip of the extension rod to a reference plate located in the head of the extensometer.

Installation is performed by assembling all the required components and placing in a predrilled borehole. In most cases the completed assembly is grouted in place.

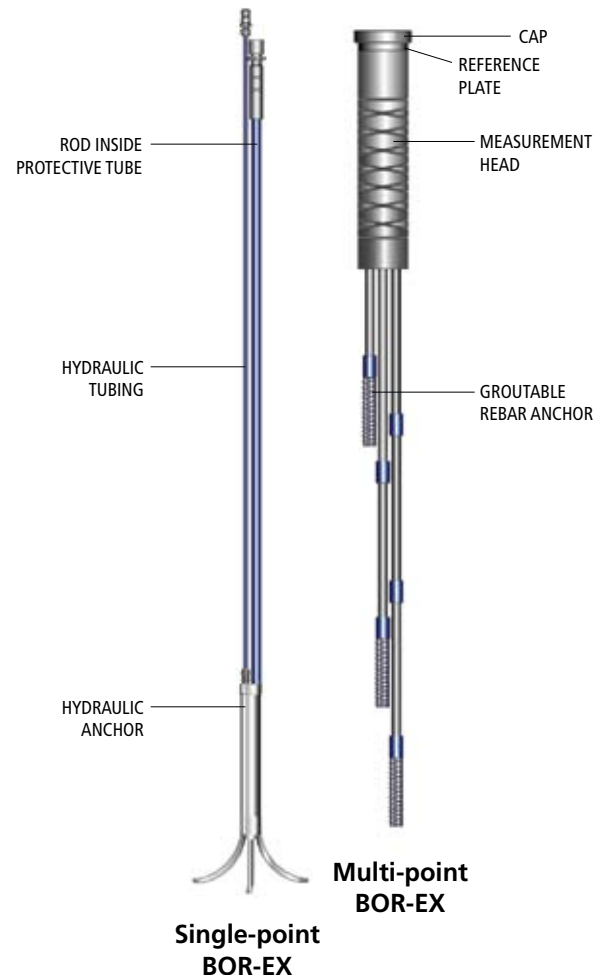

FEATURES

- Sturdy, accurate, reliable and economical
- Easy to install
- Various configurations available allowing installation in all directions and in different soil or rock types
- On-site adjustable depth anchor

ANCHORS

Groutable rebar anchor (1)

Easy to install, this type of anchor is the preferred type for downward boreholes. A good contact between the borehole wall and grout is important to insure that any movement of the surrounding material is transmitted to the anchor.

Hydraulic anchor (2)

This type of anchor is used in soils, especially when hole squeezing is anticipated. A single acting anchor contains 3 prongs, which are extended into the surrounding soil by means of a hydraulic pump. A double acting anchor has extendable prongs at both top and bottom of the anchor. The prongs, once extended, cannot be retracted. The borehole is generally grouted in place following installation.

Anchor ring with expandable springs (3)

This type of anchor is ideal for upward installations in high-quality rock mass. Installation is performed quickly and efficiently through the use of a cable to remove a pin, thus fixing the anchor firmly in place. The related boreholes do not have to be grouted after installation.

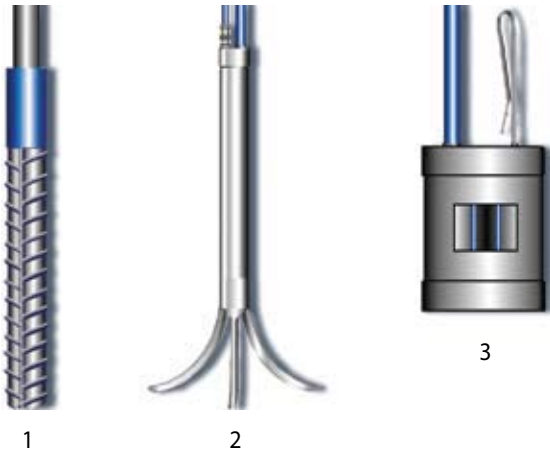

EXTENSION RODS

Two types of extension rods are available: fiberglass and stainless steel. The fiberglass rod is supplied in a continuous roll and cut to size on site. Ease and speed of installation are benefits of the fiberglass rods. Stainless steel rods are preferable where compression movements are anticipated. These rods are supplied in sections no longer than 3 m and assembled on site. Other types of material such as invar may be provided upon request.

ROD TYPE	FIBERGLASS	STAINLESS STEEL
Diameter	9.5 mm	6.4 mm
Weight	0.18 kg/m	0.25 kg/m
Protective tube	16 mm (polyethylene)	13.7 mm (PVC)
Thermal drift	6 $\mu\epsilon / ^\circ\text{C}$	17 $\mu\epsilon / ^\circ\text{C}$

PROTECTIVE TUBE

Rods must be installed in protective tubes to protect them from the injected grout and other confining material. Tubes are supplied in continuous lengths for fiberglass rods, and in sections for stainless steel rods.

ROD CENTRALIZER

Rod centralizers may be used to maintain the extension rods in position. They are highly recommended for deep installations.

ORDERING INFORMATION

Please specify:

- Model
- Number and position of measuring points
- Borehole diameter
- Installation accessories (tube and grouting plate, vent tube and installation tool kit)
- Measuring device: see BOR-EX Displacement Sensor sheet