

PENDULUM

Models DIRECT and INVERTED

APPLICATIONS

Direct and inverted pendulums are designed to accurately measure the relative internal horizontal displacement of points along a true vertical line. Pendulum applications include the following:

- Monitoring of movements within dams, dam foundations, nuclear power stations, viaducts and bridge piers
- Monitoring of structural and foundation movements in buildings
- Reference for surveying monitoring method

The instrument has specific purpose in the dam monitoring build to detect sliding or overturning of blocks.

DESCRIPTION

Direct pendulum

The direct pendulum consists of a wire suspended from the upper point and a reading station fixed to the structure at the lower point. The wire is tensioned by a suspended weight submerged in a damper tank.

Inverted pendulum

The fixed end of the inverted pendulum is grouted at the lower point of the system. A float tensions the wire vertically. When anchored to a fixed point in the foundation, it measures absolute displacement of points along the wire.

The monitoring of the wire position for both direct and inverted pendulums can be done manually and/or electrically with a remote readout unit (ref: Model RxTx Teependulum – see separate brochure). The method of reading depends upon the concept of monitoring, the expected values of movements, and the accuracy required.

The pendulum may be equipped with a Z axis reading table, for vertical deformation.

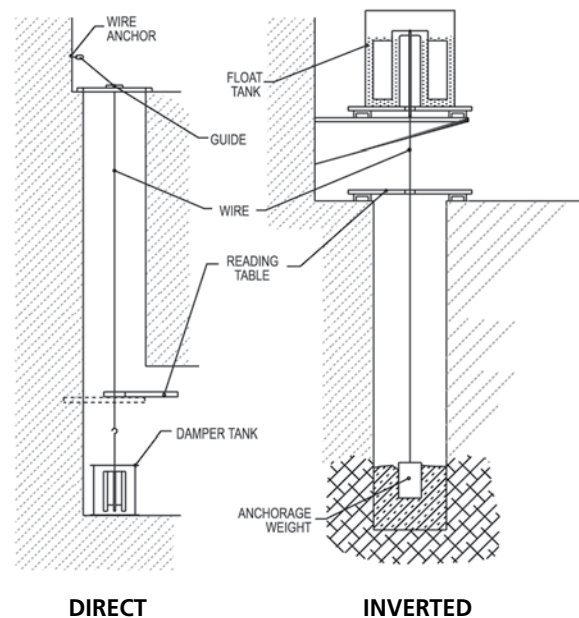

FEATURES

- High accuracy and resolution
- Long-term reliability
- Accuracy greater than with geodesic surveys
- Regular monitoring without frequent costly surveys
- Teependulum, for remote readings and automatic data acquisition

MANUAL READING OPTIONS AND INTERPRETATIONS

a) Sighting reading table Model 76

To take a reading, the operator aligns the cursors with their respective sights and with the pendulum wire. The positions of the cursors are read directly off the scale and the vernier cursor. The readings are converted to wire displacement values using the chart provided with each reading station.

b) Optical coordinoscope Model MVR

The setup consists of a reference base permanently installed at the reading point. The coordinoscope is then installed on its reference section respectively at X and Y axes on the base frame. Measurements are taken by focusing or aiming the lens at the pendulum wire and by reading the current lateral displacement on the vernier.

SPECIFICATIONS

PENDULUM COMPONENTS

Direct pendulum	Stainless steel or invar wire Upper hook and vee-shaped guide bracket Wire tensioning weight and hook Damper tank
Inverted pendulum	Wire (same as for direct pendulum) Anchoring weight PVC float and float tank assembly

MODEL 76

Range	± 15 mm
Resolution	0.1 mm
Accuracy	0.5 mm
Reading station component	Stainless steel table (includes scales, cursors, sights and chart for evaluating wire position)

MODEL MVR

Range	400 mm
Accuracy	0.02 mm
Focal range	± 50 mm
Overall dimensions	500 x 500 mm

ACCESSORIES

- Mounting brackets

ORDERING INFORMATION

Please specify:

- Type of pendulum
- Wire length (if non-standard)
- Accessories
- Manual or remote reading station

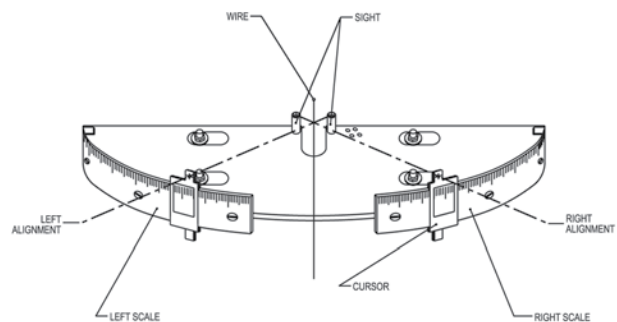

Reading Table Model 76