

# Model 800P Portable Tiltmeter

Model 800P Portable Tiltmeter is an economical hand-held instrument for a wide variety of monitoring and

measurement applications. It offers precision and repeatability previously unavailable in an instrument of this type.



Model 800P Portable Tiltmeter

## CONVENIENTLY MEASURE MOVEMENT, LEVEL AND ANGULAR POSITION

When continuous monitoring is not required, use Model 800P to make scheduled measurements at an unlimited number of points. Applications include monitoring the long-term deformation of structures and foundations, measuring mechanical response to applied loads, and surveying surface level and flatness. With the Tilt Plate Option, measurements are taken from tilt plates that have been cemented or bolted to any horizontal or vertical surface. Indexing bars on the bottom and sides of the tiltmeter enable you to reposition it exactly, every time.

With the Metrology Option, the instrument base and sides each contain three steel balls in a triangular pattern. The Metrology Option enables you to measure the flatness or inclination of any surface. Software is available to convert a set of inclination measurements into a contour map of surface relief.

## PROVEN TECHNOLOGY

Model 800P has improved on the sensitivity and repeatability of comparable Swiss-made instruments, yet its price is considerably lower. This superior performance is achieved by using a precision electrolytic transducer as the sensing element.

Similar to a spirit level, the 800P electrolytic transducer converts changes in angular position to resistance changes measured by the tiltmeter's electronics. With no mechanical moving parts to drift or wear out, the sensing element and solid state electronics will provide years of trouble-free operation. Many electrolytic transducers installed in the 1940s are still in use!

## FOR SURVEYING:

- Surface Flatness
- Settlement
- Retaining Walls
- Foundations
- Building
- Bridges
- Columns
- Roofs
- Tunnels
- Tanks
- Machinery

Angular position measured with the Model 800P is referenced to the unchanging vertical gravity vector. This important feature eliminates the time and expense of locating a stable external datum. Simply position the tiltmeter on the surface to be surveyed and begin your measurements.

## READING & RECORDING DATA

Your Model 800P Portable Tiltmeter is conveniently read with the easy to use Model 870 Readout Module. This unit powers the tiltmeter and plugs into any digital multimeter for display. You simply read the displayed data and record them in your logbook.

Graphs of movement vs. time and of tilt direction and magnitudes (tilt vectors) are easily generated by entering these data into a spreadsheet or our TBASEII Software package.

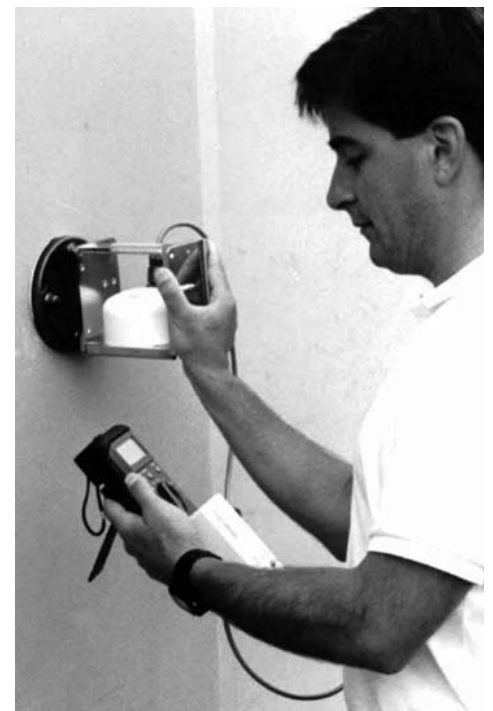

Measure inclination of any horizontal or vertical surface

The complete 800P Portable Tiltmeter system includes the following components:

- Surface Flatness
- Model 800P Portable Tiltmeter
- Model 870 Readout Module with batteries and 1.5 meter (5 ft) cable
- 4-digit multimeter for data display
- Multimeter probes for other multimeter uses
- Padded, unbreakable carrying case

When using tilt plates, the following may be ordered for each project:

- Ceramic tilt plates (P/N 1263)
- Stainless steel tilt plates (P/N 1273)
- Protective covers for tilt plates (P/N 84041)
- Tilt plate cement

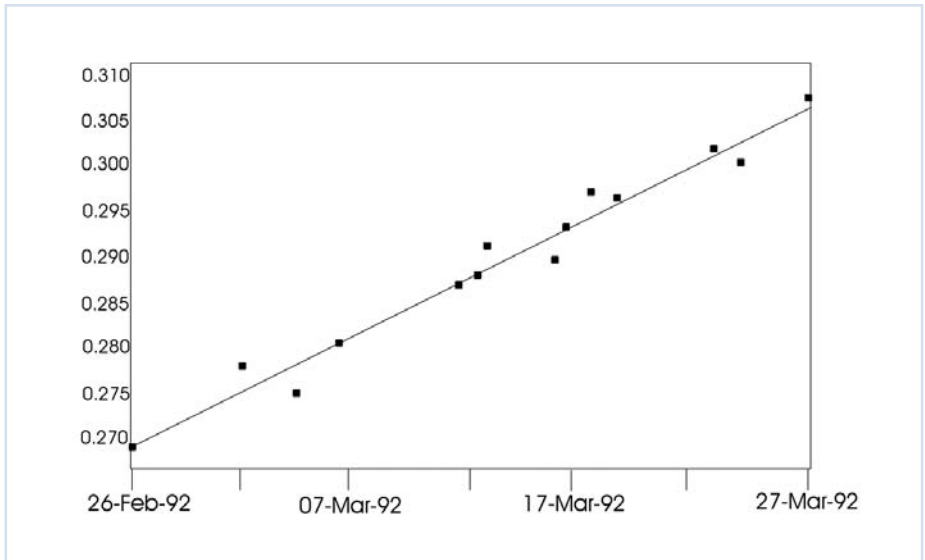

Retaining wall tilt measured with Portable Tiltmeter/Tilt Plate

MODEL 800P PORTABLE TILTMETER	
<b>OUTPUT CHANNELS</b>	Inclination, temperature
<b>RESOLUTION</b>	0.0001 arc degree (0.36 arc second)
<b>REPEATABILITY</b>	±0.004 degree typical
<b>ANGULAR RANGE</b>	+5 degrees from null position
<b>LINEARITY</b>	1% of full scale
<b>FILTERING</b>	2-pole Butterworth low-pass filter for removing noise from vibration or jitter -25°C to +70°C operational, -30°C to +100°C storage. Sealed for use in damp environments; nonsubmersible
<b>ENVIRONMENTAL</b>	
<b>DIMENSIONS</b>	143 x 102 x 127 mm (5.6 x 4 x 5 inches)
<b>WEIGHT</b>	2.7 kg (6 lb)
<b>MATERIALS</b>	Stainless Steel; plastic sensor housing



Model 800P System

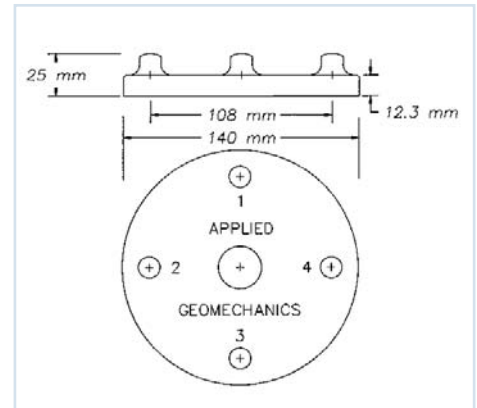

Tilt Plate

MODEL 800P READOUT MODULE	
<b>FUNCTION</b>	Powers tiltmeter, switches tiltmeter output to digital multimeter
<b>RESOLUTION</b>	Using four-digit multimeter: 0.001 arc degree (3.6 arc seconds) at tilt greater than 1 arc degree, 0.0001 arc degree (0.36 arc second) at tilt less than 1 arc degree
<b>POWER</b>	One 9-volt battery provides up to 24 hours of continuous tiltmeter operation
<b>SIZE</b>	111 x 62 x 32 mm (4.4 x 2.4 x 1.3 inches) with 1.5 m (5 ft) cable
<b>WEIGHT</b>	285 g (0.6 lb) including batteries
<b>MATERIALS</b>	ABS plastic



Model 870 Readout Module and Multimeter

**ORDER CODES:**

**Model A800P-**  1 Tiltmeter  
 2 Tiltmeter & Measurement System

**1**  
**2**

**USEFUL ACCESSORIES:**

**NO###** PVC-jacketed cable, 6mm dia. (see reverse), specify length  
**S0-20/6** Neoprene cable, 9mm dia. (see reverse), specify length  
**SPLICE** Waterproof cable splice



environmental systems & services  
 8 River Street, Richmond VIC 3121 Australia  
 T + 61 3 8420 8999 | F + 61 3 8420 8900  
 geotechnical@esands.com | [www.esands.com](http://www.esands.com)

